

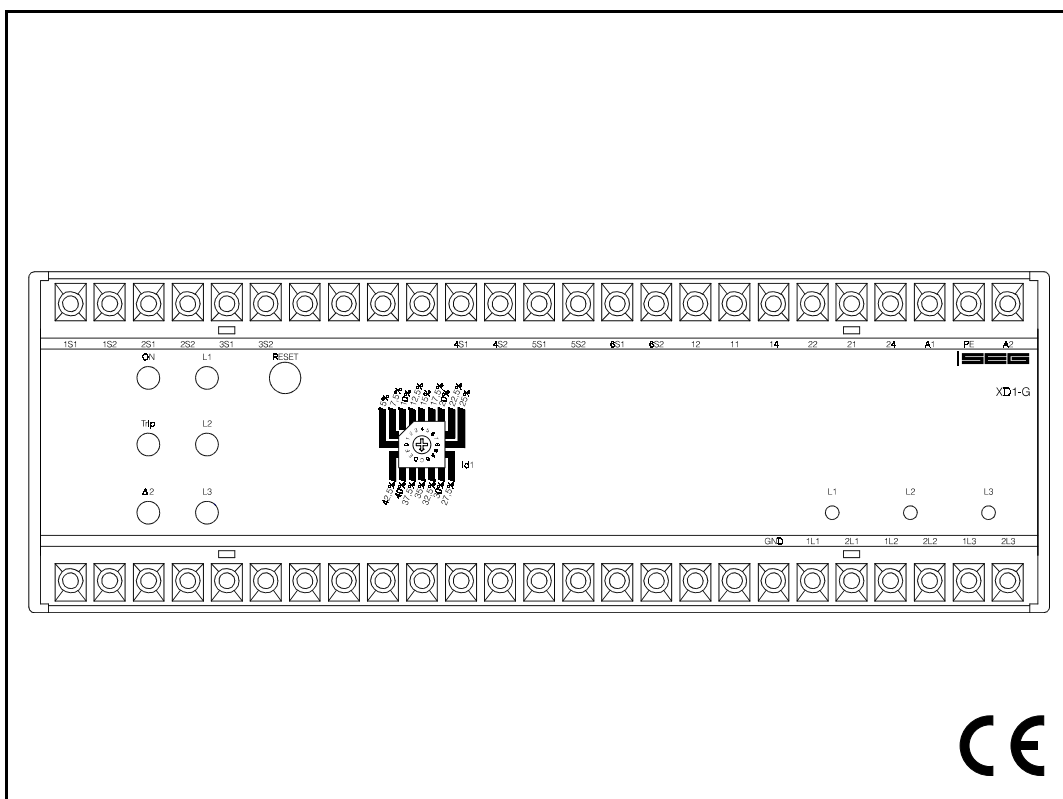

# **XD1-G** - Generator differential protection relay



## Contents

<b>1</b>	<b>Application and features</b>
<b>2</b>	<b>Design</b>
<b>3</b>	<b>Working Principle</b>
3.1	Operating principle of the differential protection
3.2	Working principle of the C.T. saturation detector SAT
3.3	Block diagram
<b>4</b>	<b>Operation and settings</b>
4.1	Parameter setting
4.2	Setting of the pickup value for the differential current Id1 fine tripping characteristic
<b>5</b>	<b>Relay testing and commissioning</b>
5.1	Connection of the auxiliary voltage
5.2	Checking the set values
5.3	Secondary injection test
5.3.1	Test equipment
5.3.2	Checking of the pickup and dropout value
5.3.3	Checking the trip delay
5.4	Primary injection test
5.5	Adjustment of the interposing C.T.s
5.6	Maintenance
5.7	Function test
<b>6</b>	<b>Technical Data</b>
6.1	Relay case
6.2	Technical Data
<b>7</b>	<b>Orderform</b>

## 1 Application and features

Protection devices for electrical systems minimize fault damages, assist in maintaining power system stability and help to limit supply interruptions to remaining consumers.

Differential protection for generators, based on the well-known Merz-Price circulating current principle, which compares currents in two measuring points, e.g. the current to the star point of a generator with the current to the busbar, is a fast and selective form of protection. Faults lying within the protected zone are cleared very rapidly, thus limiting fault damage.

Types of faults occurring within the protected zone requiring immediate tripping and isolation of the generators are:

- faults between statorwindings
- stator earth faults
- ground faults and faults between phases outside the generator but within the protected zone, e.g. at the generator terminals or on the external connections.

An extremely important feature of any generator differential protection is that it should remain absolutely stable (i.e. no tripping command) for faults or any other transient phenomena outside the protected zone.

For the protection of generators relay type **XD1-G** is available at a very competitive price. The basic version of this relay absolutely meets the requirements of generator differential protection outlined above.

The basic version of the relay can be extended even later by the addition of extra cards. By using a new method of evaluating current signals, the relay can determine whether C.T. saturation is due to internal or external faults and either trip or stabilize accordingly. Thus this extended relay (type **XD1-G SAT**) is particularly appropriate for:

- Different sets of C.T.s
- Retrofitting
- Difficulty conditions
- High-quality items to protect
- High mains power
- Motor feeders

The relay **XD1-T** of the *PROFESSIONAL LINE* has the following special features:

- Fault indication via LEDs
- Extremely wide operating ranges of the supply voltage by universal wide-range power supply
- Very fine graded wide setting ranges
- Extremely short response time
- Compact design by SMD-technology
- Static, three-phase differential protection relay
- Dual slope percentage bias restraint characteristic with adjustable bias setting
- Electronical storage for indication of the faulty phase
- Applicable for 45 to 65 Hz
- Burden < 0.05 VA at rated current
- Setting ranges:
  - Differential current:*  
5 to 42.5 %  $I_N$  in 15 steps
  - Bias slope:*  
10 % of actual current (fixed)
- Isolation between all independent inputs
- High electromagnetic compatibility
- The use of precision components guarantees high accuracy
- Permissible temperature range:  
-20°C to +70°C
- According to the requirements of VDE 0435, part 303 and IEC 255

Extended version (type suffix **SAT**)

- Ability to recognize saturation of the main current transformers
- Extremely stable even during saturation of current transformers
- Current transformer burden and class requirements are low
- Additional printed circuits for recognition of saturated C.T.s can be added at a later stage, e.g. as the power system develops and fault levels increase

Further features of the unit **XD1-G**:

- High reliability and easy-to-service arrangement
- Plug in design makes it possible to simplify extension of the basic unit
- LED indication of operating conditions

## 2 Design

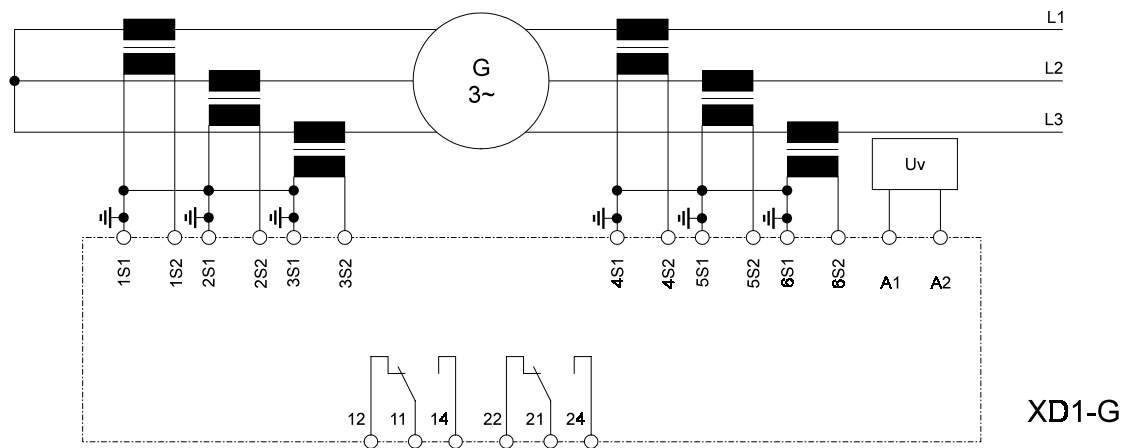

Figure 2.1: Connection diagram

### Analogue inputs

The analogue input signals are connected to the protection device via terminals 1S1 - 3S2 and 4S1 - 6S2.

### Auxiliary voltage supply

Unit **XD1-G** needs a separate auxiliary voltage supply. Therefore a DC or AC voltage must be used. Unit **XD1-G** has an integrated wide range power supply. Voltages in the range from 19 - 390 V DC or 36 - 275 V AC can be applied at connection terminals A1 and A2.

### Contact positions

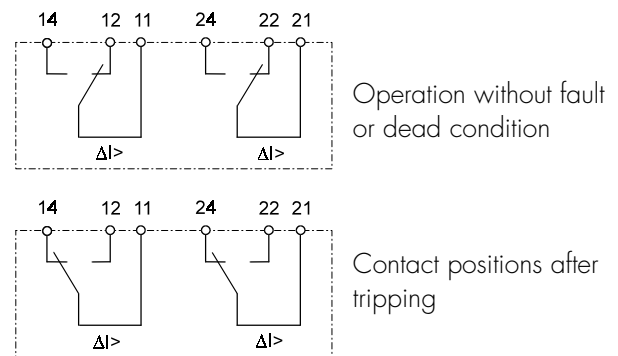

Figure 2.2: Contact positions of the output relays

### 3 Working Principle

#### 3.1 Operating principle of the differential protection

The fundamental operating principle of generator differential protection is based on a comparison of the current to the star point with the current to the busbar. For an ideal generator the currents entering and leaving the generator must be equal. Or according to Kirchhoff's first law "the vector sum of currents entering and leaving any point must be zero". If the sum  $I_d$  of currents is not zero, an internal fault is indicated.

The basic equipment of relay **XD1-G** recognizes these differential currents  $I_d$  and the relay gives the tripping command according to the precision measuring characteristic (see Tripping characteristics).

To explain the function at **XD1-G** the working principle is shown in figure 3.1.

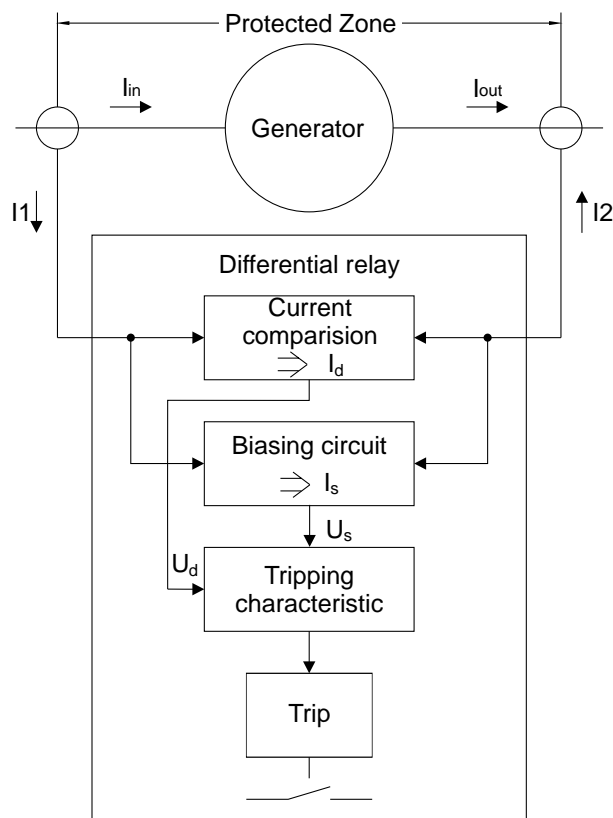

Figure 3.1: Working principle **XD1-G**  
 $I_d$  = differential (tripping) current  
 $I_s$  = stabilizing current

#### 3.2 Working principle of the C.T. saturation detector SAT

With many transformer differential protection systems, relay instability may cause to trip if the main current transformers saturate. In the transient condition of saturation the C.T.s on both ends of the protected zones do not produce the correct secondary current according to the primary current. The differential relay measures a differential current on the secondary C.T. side which is not present on the primary side. Hence a false tripping might occur.

Such transient phenomena causing C.T. saturation may occur due to:

- Heavy through faults (external short circuit)
- Starting of big motors
- Magnetizing inrush currents of transformers

The figure 3.2 explains the saturation of the C.T. core due to a short circuit current. In the instant of a short circuit often a DC-component is present in the current. The high primary current induces a flux in the C.T. core, reaching the saturation level. The iron-core retains the high flux level even after the primary current falls to zero. In the time periods of saturation the C.T. does not transform the primary current to the secondary side but the secondary current equals zero.

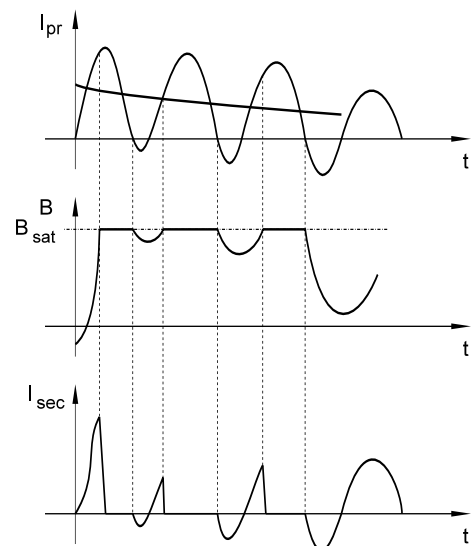

Figure 3.2: Current transformer saturation  
 $I_{pr}$  = Primary current with DC offset  
 $B_{sat}$  = Saturation flux density  
 $I_{sec}$  = Secondary current

Dissimilar saturation in any differential scheme will produce operating current.

Figure 3.3 shows the differential measurement on the example of extremely dissimilar saturation of C.T.s in a differential scheme. Fig. 3.3 shows the secondary current due to C.T. saturation during an transformer fault (internal fault). The differential current  $i_d$  represents the fault current. The differential relay must trip instantaneously.

Fig. 3.3 shows the two secondary currents in the instant of an heavy external fault, with current  $i_1$  supposed to C.T. saturation, current  $i_2$  without C.T. saturation.

The differential current  $i_d$  represents the measured differential current, which is an operating current. As this differential current is caused by an external fault and dissimilar saturation of the two C.T.s, the differential relay should not trip.

Left: **Internal fault, Single end fed**

- $i_1$  = secondary output current from saturated C.T. (theoretical)
- $i_2$  = 0; Internal fault fed from side 1 only.
- $i_d$  = measured differential current

Right: **External fault:**

- $i_1$  = as in fig. 3.3 for an internal fault
- $i_2$  = normal current from C.T. secondary on side 2
- $i_d$  = measured differential current

The wave forms for the differential current  $i_d$  for internal and external faults are seen to be different for the cases considered.

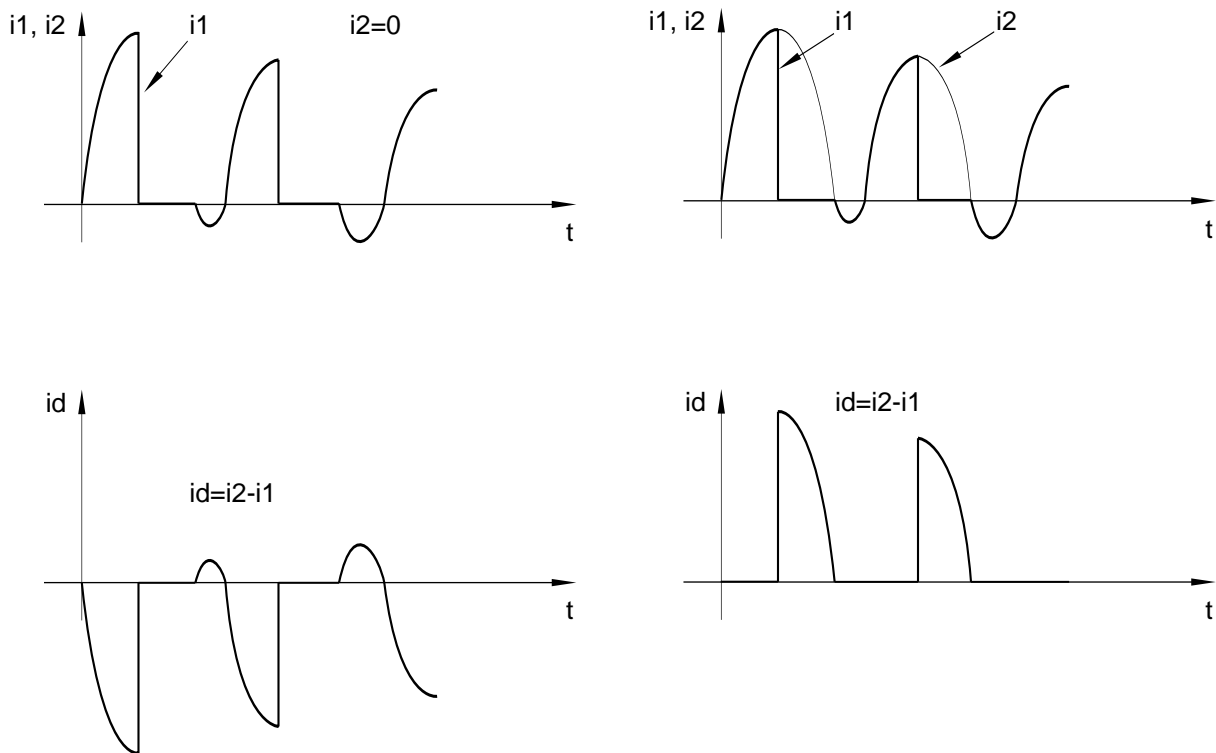

Figure 3.3: Current comparison with C.T.s saturated by DC offset in fault current wave form

The saturation detector **SAT** analyses the differential current of each phase separately. The SAT module differentiates the differential current and detects:

- Rate of change of differential current  $d(i_d)/dt$
- Sign of  $d(i_d)/dt$
- Internal / external fault
- Time period of saturation, within one cycle
- DC or AC saturation

The instant of an extreme rate of change of differential current  $d(i_d)/dt$  clearly marks the begin of a C.T. saturation.

The sign of this  $d(i_d)/dt$  value distinguishes the internal fault from an external fault.

One detected extreme  $d(i_d)/dt$  value per cycle indicates a saturation due to DC-current contents.

Whereas two extreme  $d(i_d)/dt$  values per cycle indicate a C.T. saturation caused by a high alternating current.

The logic control evaluating above informations derives:

- Only external faults lead to blocking of the trip circuit.
- In case of detected DC-current saturation the differential current measurement is blocked completely until: the transient condition ends, or an internal fault is detected (instantaneously), or AC-current saturation is detected.
- In case of detected AC-current saturation only the time periods of saturation are blocked during one cycle. This means that even under severe saturation the differential relay evaluates the differential current in „sound“ time periods. This is a major advantage to relays solely applying harmonic filters for saturation detecting.
- All detected transient phenomena change the tripping characteristic to the "coarse tripping characteristic" (pl. ref. to Technical Data).

### 3.3 Block diagram

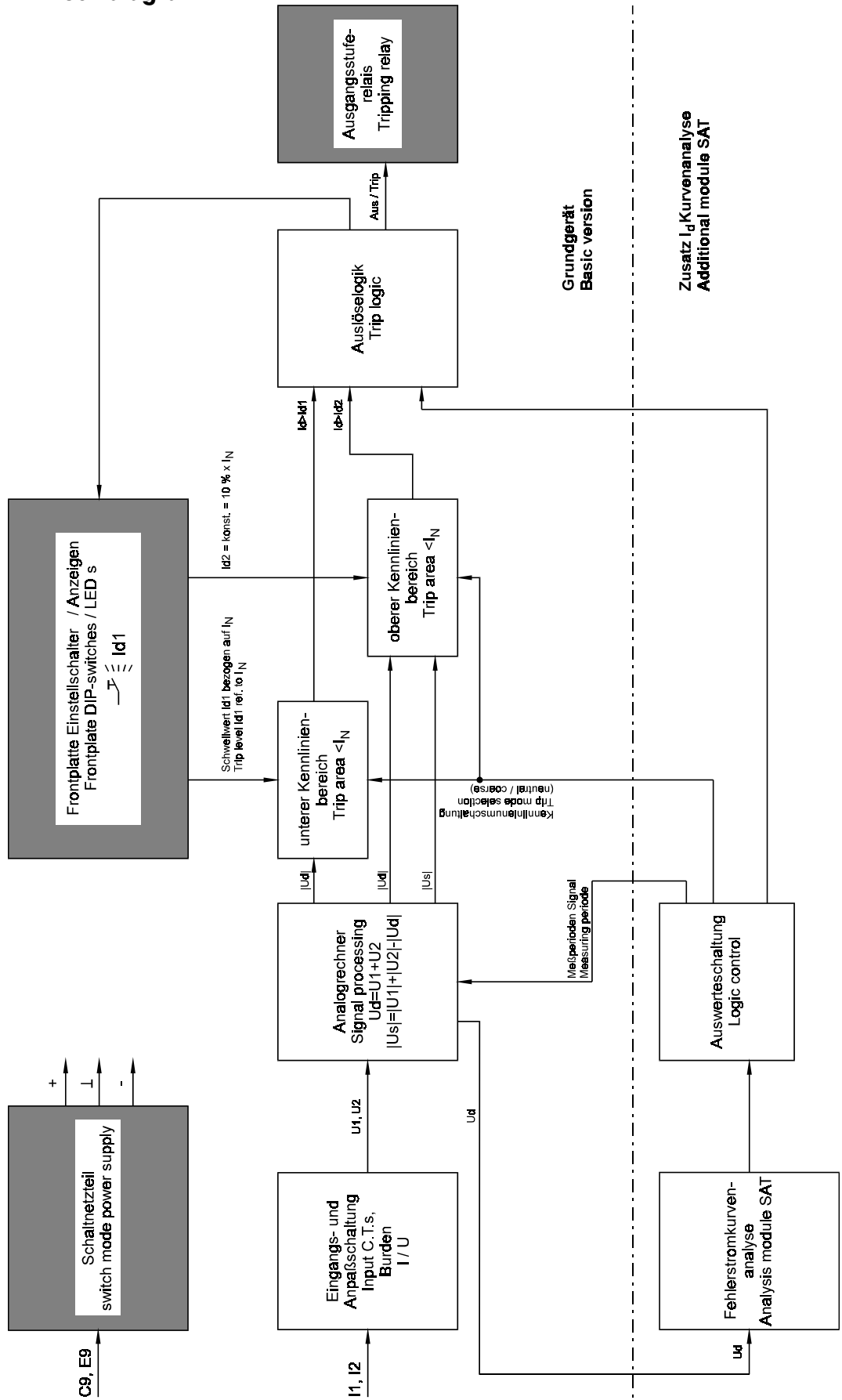

Figure 3.4: Block diagram

## 4 Operation and settings

All operating elements needed for setting parameters are located on the front plate of the *XD1-G* as well as all display elements.

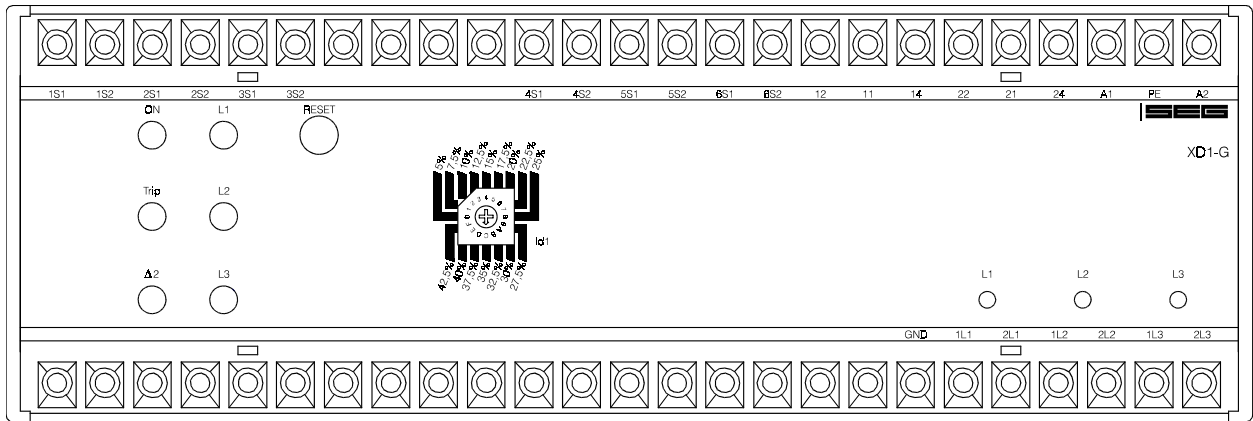

Figure 4.1: Front plate *XD1-G*

For adjustment of the unit the transparent cover has to be opened as illustrated. Do not use force! The transparent cover has two inserts for labels.

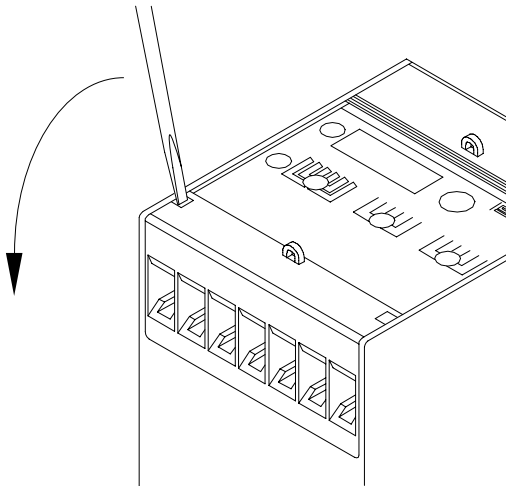

Figure 4.2: How to open the transparent cover

### LEDs

LED „ON“ is used for display of the readiness for service (at applied auxiliary voltage  $U_v$ ). LEDs L1, L2, L3 and TRIP are provided for fault indication. LED  $\Delta 2$  indicates changeover to the coarse measuring element (only with an additional SAT module).

### Reset push button

The Reset push-button is used for acknowledgement and resetting the LEDs after tripping.

### Potentiometer

The 3 potentiometers on the lower right side of the front plate are provided for adjustment of the interposing C.T.s (refer to chapter 5.5).

## 4.1 Parameter setting

For each phase the relay calculates the differential current  $I_d$  and the stabilizing current  $I_s$ . The differential current  $I_d$  is the vector difference between star point and outgoing currents. The value of differential current at which the relay responds is dependent on the stabilizing current, as shown in fig. 5 "Tripping characteristic".  $I_N$  is relay rated current (1 A or 5 A) and the two quantities  $I_d/I_N$  and  $I_s/I_N$  are scaled in multiples of rated current.

The basic version of the relay is equipped with the "fine" tripping characteristic only. The differential current  $I_d$  is adjustable from 5 % to 42.5 % of rated current. With the extended version SAT the tripping characteristic can be automatically switched from the selected "fine" to the fixed "coarse" characteristic. The biased slope characteristic (right and upper part of the characteristic) prevents incorrect operation of the relay at through faults. The lower section of the characteristic shows the minimum differential current required to operate the relay with zero or low levels of stabilizing current.

**Bias characteristic setting (fixed)**  
(related to stabilizing current  $I_s$ )

$$I_{d2} \% = I_d / I_s = 10 \%$$

**Differential current settings**  
(related to relay rated current  $I_N$ )

$$I_{d1} \% = I_d / I_N = 5 \% \dots 42.5 \%$$

For stability during transient conditions with extended version (SAT) of the relay the protection automatically changes over to the fixed "coarse" tripping characteristic. In this case the following settings apply:

**Bias setting (related to  $I_s$ ):**

$$I_{d2} \% = I_d / I_s = 60 \%$$

**Differential setting (related to  $I_N$ ):**

$$I_{d1} \% = I_d / I_N = 100 \%$$

The relay has a stepped tripping characteristic:

- For differential currents up to rated current the time delay is 100 ms.
- For differential currents greater than rated current the relay trips instantaneously (approx. 40 ms).

## 4.2 Setting of the pickup value for the differential current $I_{d1}$ fine tripping characteristic

The pickup value of the fine tripping characteristic can be adjusted in the lower section by means of the step switch  $I_{d1}$  in the range from 5 - 42.5 %. (Scale 2.5 %).

Example:

Adjustment of the characteristic is shown on the following diagram:

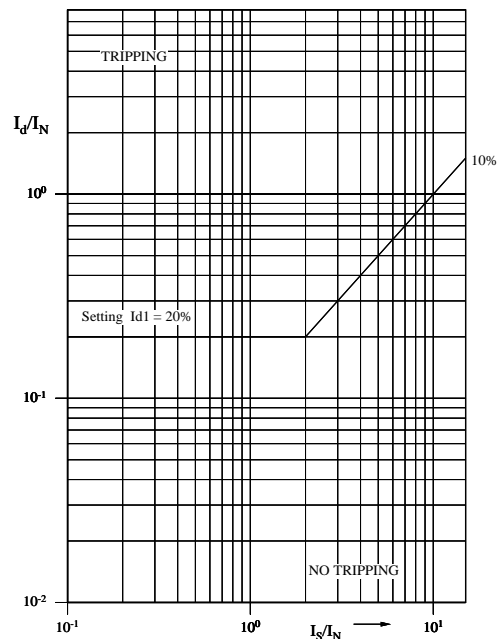

Figure 4.3: Diagram tripping characteristic

For this step-switch for  $I_{d1}$  has to be in the following positions:

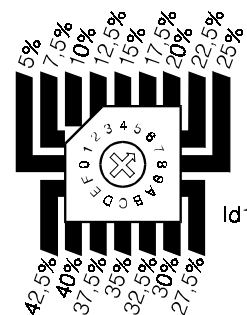

Figure 4.4: Adjustment of step switch

## 5 Relay testing and commissioning

The following test instructions should help to verify the protection relay performance before or during commissioning. To avoid a relay damage and to ensure a correct relay operation, be sure that:

- the auxiliary power supply rating corresponds to the auxiliary voltage on site
- the rated voltage corresponds to the plant data on site,
- the voltage transformer circuits are connected to the relay correctly
- all control- and measuring circuits as well as the output relays are connected correctly.

### 5.1 Connection of the auxiliary voltage

#### Note!

Prior to switch on the auxiliary power supply, be sure that the auxiliary supply voltage corresponds with the rated data on the type plate.

When the auxiliary power supply is switched on (terminals A1 /A2) please observe that the LED "ON" is alight.

### 5.2 Checking the set values

Due to a check of the DIP-switch positions, the actual thresholds can be established.

The setting values can be corrected, if necessary by means of the DIP-switches.

### 5.3 Secondary injection test

#### 5.3.1 Test equipment

- Ammeter, class 1 or better,
- Auxiliary voltage supply corresponding to the nominal auxiliary voltage of the device
- Single-phase AC supply (adjustable from 0 -  $1 \times I_N$ )
- Timer for the measuring of the trip delays
- Switching device
- Test leads and tools

#### NOTE!

Before this test is initiated by means of secondary current, it must be ensured that the relay cannot cause any switching actions in the system (shut-down risk).

#### 5.3.2 Checking of the pickup and dropout value

When checking the pickup value for  $I_{d1}$ , the analog input signals of the single phase alternating test current have to be fed to the relay via terminals 1S1 - 1S2.

When testing the pickup value, the alternating test current must first be lower than the set pickup value for  $I_{d1}$ .

Then the current will be increased until the relay picks up. The value that can be read from the ammeter may not deviate by more than  $\pm 2.5\%$  of the setting value  $I_{d1}$ . The tripping values  $I_{d1}$  for the other current inputs should be checked accordingly.

#### 5.3.3 Checking the trip delay

For checking the tripping time (time element of the relay), a timer is connected to the contact of the trip relay.

The timer has to be started simultaneously with connection of the test current and must be stopped when the relay trips.

### 5.4 Primary injection test

Generally, a primary injection test could be carried out in the similar manner as the secondary injection test above. Since the cost and potential hazards are very high for such a test, primary injection tests are usually limited to very important protective relays in power system.

## 5.5 Adjustment of the interposing C.T.s

The correct connection and accurate adjustment of the CTs can be checked with a voltmeter. For this 7 terminals are provided at the lower terminal strip. The associated adjustment potentiometers are arranged above these terminals. Differences of the main CT up to 1.5 %  $I_N$  can be adjusted by the potentiometers.

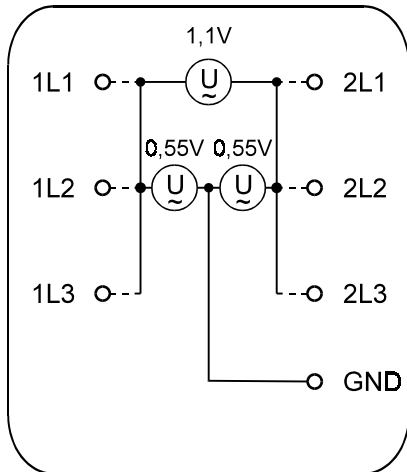

Figure 5.1: Connection sockets at the front plate

Information about measuring results can be found on the following table.

a)	Measuring 1 (1L1 - GND) Measuring 2 (2L1 - GND) Measuring 3 (1L1 - 2L1)	550 mV 550 mV 1100 mV	Correct connection
b)	Measuring 1 (1L1 - GND) Measuring 2 (2L1 - GND) Measuring 3 (1L1 - 2L1)	550 mV 550 mV 0 mV	Current flow of a C.T. (S1 and S2) is mixed-up
c)	Measuring 1 (1L1 - GND) Measuring 2 (2L1 - GND) Measuring 3 (1L1 - 2L1)	550 mV 550 mV 550 mV	Phase position mixed-up (e.g. one current from phase L1, the other one from phase L2)
d)	Measuring 1 (1L1 - GND) Measuring 2 (2L1 - GND) Measuring 3 (1L1 - 2L1)	550 mV 550 mV 950 mV	Current flow and phase position of a C.T. is mixed-up

Table 5.1: Measuring results

Measuring results are based on values at rated relay current. If the test is carried out at partial current, the values differ accordingly.

Minimal measuring value deviations, e.g. due to unequal transformer ratio of the C.T.s, can be rectified by balancing the corresponding potentiometer. For phases L2 and L3 measurements a) - d) to be done in similar manner.

## 5.6 Maintenance

Maintenance testing is generally done on site at regular intervals. These intervals vary among users depending on many factors: e.g. the type of protective relays employed; the importance of the primary equipment being protected; the users past experience with the relay, etc.

For static relays like *XD1-G*, maintenance testing will be performed at least once a year according to the experiences.

## 5.7 Function test

### Attention!

Disconnect all leads for adjusting the interposing C.T.s and perform the following function test:

Load the generator with minimum 50% load. Assure that the tripping of the generator C.B. does not cause unwanted damages (blackout).

To operate the differential relay use a shorting link between one of the phase measuring sockets and GND, e.g. connect 1L1 to GND. The relay should trip immediately. If no trip occurs, make sure that the load current exceeds the set value of  $I_{d1}$ .

## 6 Technical Data

### 6.1 Relay case

Relay *XD1-G* is designed to be fastened onto a DIN-rail acc. to DIN EN 50022, the same as all units of the *PROFESSIONAL LINE*.

The front plate of the relay is protected with a sealable transparent cover (IP40).

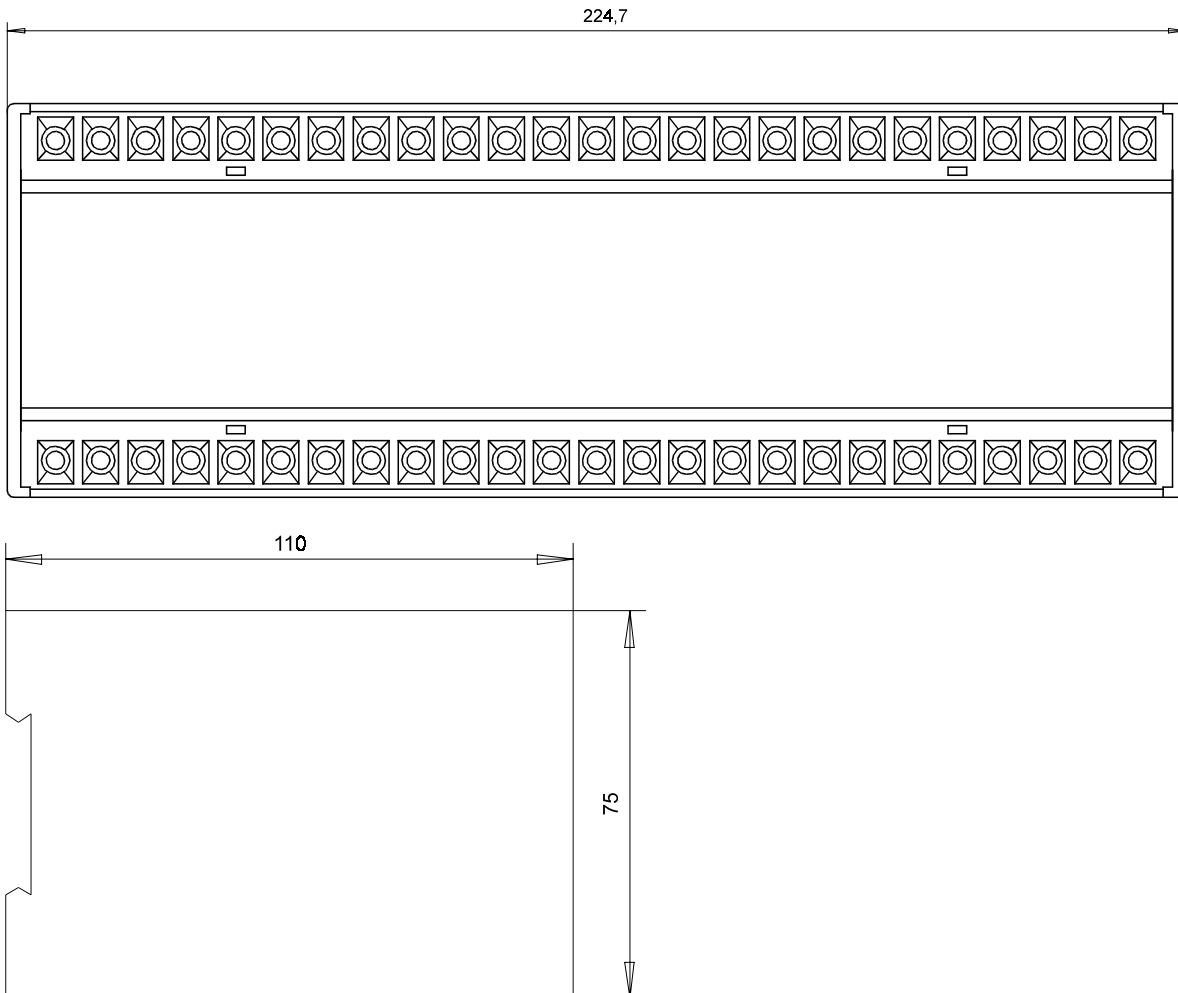

Table 6.1: Dimensional drawing

#### Connection terminals

The connection of up to a maximum  $2 \times 2.5 \text{ mm}^2$  cross-section conductors is possible. For this the transparent cover of the unit has to be removed (see para. 3).

## 6.2 Technical Data

### Measuring input

Rated data:  
 Rated current 1 A / 5 A  
 Rated frequency  $f_N$ : 50 - 60 Hz

Power consumption  
 in current circuit:  
 at  $I_N = 1\text{ A}$  < 0.1 VA  
 at  $I_N = 5\text{ A}$  < 0.5 VA

Thermal withstand capability  
 in current circuit:  
 dynamic current withstand (half-wave) 250 x  $I_N$   
 for 1 s 100 x  $I_N$   
 for 10 s 30 x  $I_N$   
 continuously 4 x  $I_N$

### Auxiliary voltage

Rated auxiliary voltages  $U_H$ :  
 35 - 275 V AC ( $f = 40 - 70\text{ Hz}$ )  
 19 - 390 V DC

### General data

Dropout to pickup ratio: > 97%  
 Returning time: < 50ms  
 Returning time after tripping: 100ms  $\pm$  10ms  
 Minimum operating time: 30ms

### Output relays

The output relay has the following characteristics:

Maximum breaking capacity: 250 V AC / 1500 VA / continuous current 6 A

For DC-voltage:

	ohmic	L/R = 40 ms	L/R = 70 ms
300 V DC	0.3 A/90 W	0.2 A/63 W	0.18 A/54 W
250 V DC	0.4 A/100 W	0.3 A/70 W	0.15 A/40 W
110 V DC	0.5 A/55 W	0.4 A/40 W	0.20 A/22 W
60 V DC	0.7 A/42 W	0.5 A/30 W	0.30 A/17 W
24 V DC	6.0 A/144 W	4.2 A/100 W	2.50 A/60 W

Max. rated making current: 64 A (VDE 0435/0972 and IEC 65/VDE 0860/8.86)  
 Making current: min. 20 A (16 ms)  
 Mechanical life span: 30 x 10<sup>6</sup> operating cycles  
 Electrical life span: 2 x 10<sup>5</sup> operating cycles at 220 V AC / 6 A  
 Contact material: silver cadmium oxide (AgCdO)

## System data

Design standard:	VDE 0435, T303, IEC 255-4, BS142
Specified ambient service Storage temperature range:	- 40°C to + 85°C
Operating temperature range:	- 20°C to + 70°C
Environmental protection class F as per DIN 40040 and per DIN IEC 68, part 2-3:	relative humidity 95 % at 40°C for 56 days
Insulation test voltage, inputs and outputs between themselves and to the relay frame as per VDE 0435, part 303 and IEC 255-5:	2.5 kV (eff.), 50 Hz; 1 min
Impulse test voltage, inputs and outputs between themselves and to the relay frame as per VDE 0435, part 303 and IEC 255-5:	5 kV; 1.2 / 50 µs; 0.5 J
High frequency interference test voltage, inputs and outputs between themselves and to there lay frame as per IEC 255-6:	2.5 kV/1MHz
Electrostatic discharge (ESD) test as per VDE 0843, part 2 IEC 801-2:	8 kV
Radiated electromagnetic field test as per VDE 0843, part 3 IEC 801-3:	electric field strength 10 V/m
Electrical fast transient (Burst) test as per VDE 0843, part 4 IEC 801-4:	4 kV/2.5 kHz, 15 ms
Radio interference suppression test as per DIN/VDE 57871:	limit value class A
Mechanical tests: Shock:	class 1 as per DIN IEC 255 part 21-2
Vibration:	class 1 as per DIN IEC 255 part 21-1
Degree of protection:	IP40 at closed front cover
Weight:	ca. 1.5 kg
Mounting position:	any
Relay case material:	self-extinguishing
Overvoltage class:	III

Technical data subject to change without notice!

# Tripping characteristics

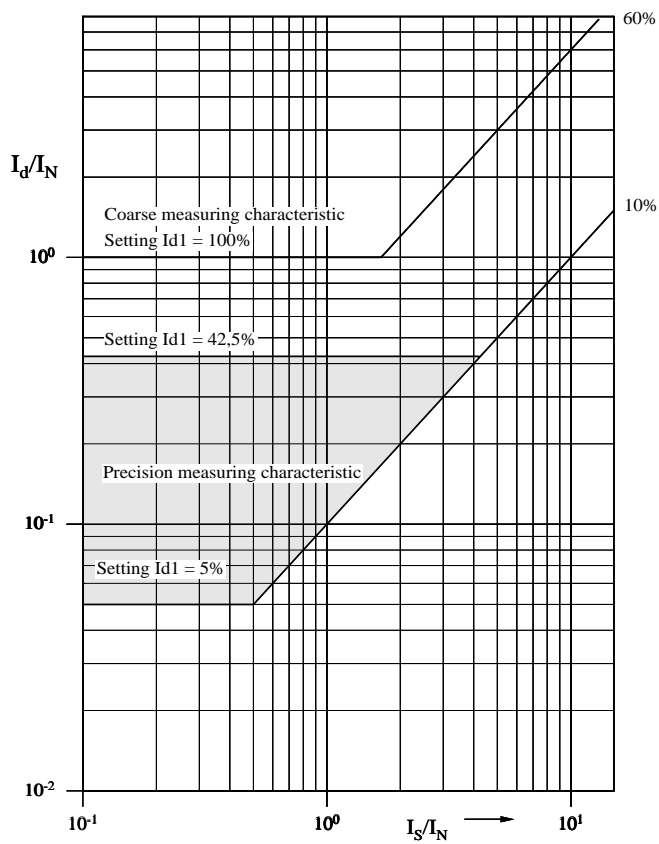

Figure 6.1: Tripping range

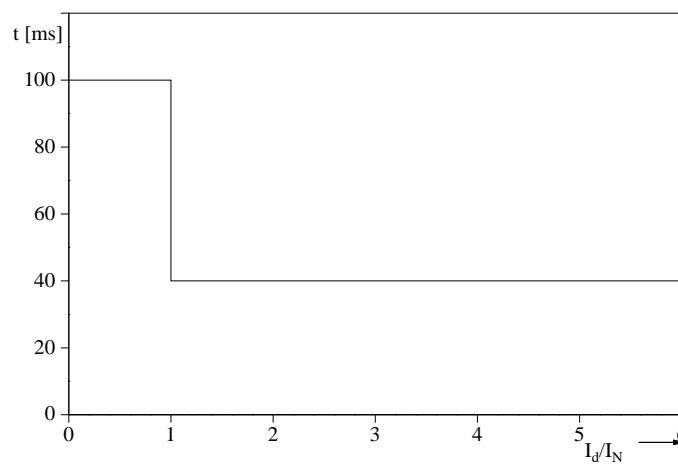

Figure 6.2: Tripping time

## Accuracy details

for  $I_s < I_N$ :

$$e = \left| \frac{I_{dtrip} - I_{dset}}{I_N} \right| \cdot 100\%$$

for  $I_s \geq I_N$ :

$$e = \left| \frac{I_{dtrip} - I_{dset}}{I_s} \right| \cdot 100\%$$

where

$e$  = relative error

$I_s$  = stabilizing current

$I_N$  = rated current

$I_{dtrip}$  = measuring differential current which results in tripping

$I_{dset}$  = differential current setting

Note:

The accuracy details quoted are based on interposing current transformer with exact correction ratio.

Accuracy at reference conditions:

- Temperature range  
-5°C...40°C  $e \leq 2.5\%$
- Frequency range  
50 Hz...60 Hz:  $e \leq 2.5\%$

If the operating temperature or frequency are outside the ranges quote, additional errors are:

- Temperature range  
-20°C...70°C:  $e_{add} < 2,5\%$
- Frequency range  
45 Hz...66 Hz:  $e_{add} = 1\%$

## 7 Orderform

Differential protection relay		<b>XD1-</b>				
Generator protection (Motor)		<b>GL</b>				
Primary rated current	1 A		<b>1</b>			
	5 A		<b>5</b>			
Secondary rated current	1 A			<b>1</b>		
	5 A			<b>5</b>		
none					*	
Latching relay and manual reset					<b>SP</b>	
none						*
Extra equipment for reliable functioning during CT saturation <sup>1</sup>						<b>SAT</b>

\* Please leave box empty if option is not desired

**Setting-list XD1-G**

Project: \_\_\_\_\_ SEG job.no.: \_\_\_\_\_

Function group: = \_\_\_\_\_ Location: ± \_\_\_\_\_ Relay code: - \_\_\_\_\_

Relay functions: \_\_\_\_\_ Date: \_\_\_\_\_

**Setting of parameters**

Function		Unit	Default settings	Actual settings
Id1	Differential current	% In	5	